

KIA Genuine Accessories

Kit Overview

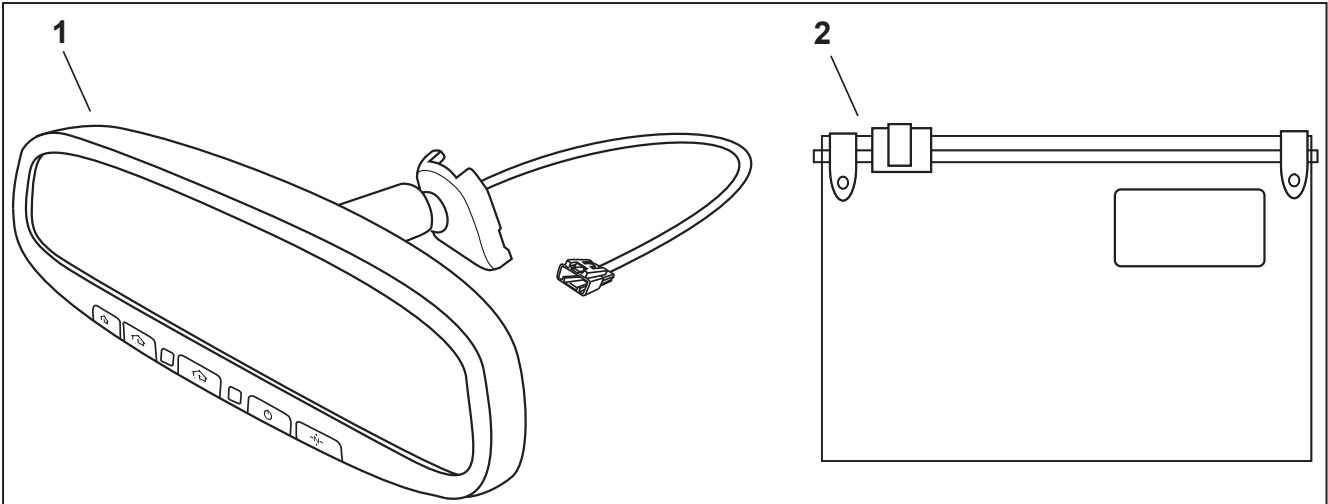

| No. | Qty. | Description |
|-----|------|---------------------------------|
| 1 | 1 | EC Mirror w/ HomeLink & Compass |
| 2 | 1 | Hardware Kit |

Hardware Kit Review

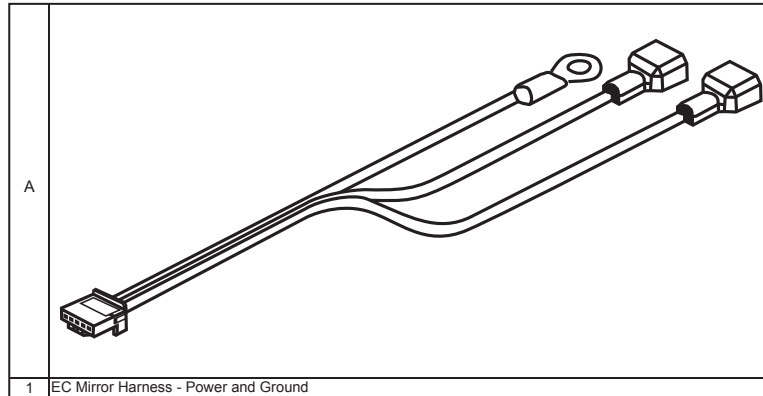

| | |
|---|--------------------------------------|
| 1 | EC Mirror Harness - Power and Ground |
|---|--------------------------------------|



| | |
|---|---------------------------|
| 1 | Installation Instructions |
|---|---------------------------|

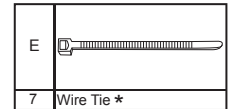

| | |
|---|------------|
| 7 | Wire Tie * |
|---|------------|



| | |
|---|-----------------------|
| 1 | Quick Reference Guide |
|---|-----------------------|

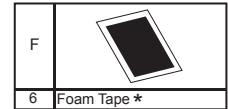

| | |
|---|-------------|
| 6 | Foam Tape * |
|---|-------------|

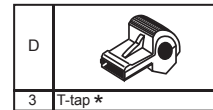

| | |
|---|---------|
| 3 | T-tap * |
|---|---------|

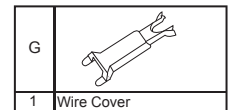

| | |
|---|------------|
| 1 | Wire Cover |
|---|------------|

* Extra components intentionally placed in kit as spares. Please follow directions for proper placement of each component.

| |
|--------------------|
| Hardware Kit Total |
| 23 |

WIRE CODES

Wires are either solid color or striped wires. The first color in the description indicates the base color of the wire, the second indicates the color of the stripe (or tracer).

Example:

Solid Color Wire



Black wire

Striped Wire

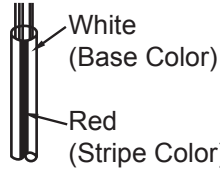

White w/ Red Tracer wire

CONNECTOR DIAGRAMS

Connector diagrams show the harness side view. **The pin numbers are from the harness side view.**

Example:

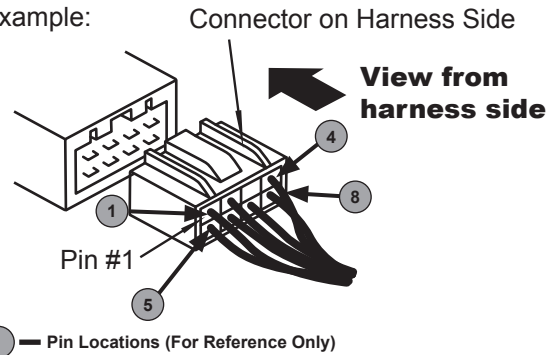

DISCONNECTING CONNECTORS

When disconnecting the wires, grasp the connectors, not the wires.

Example:

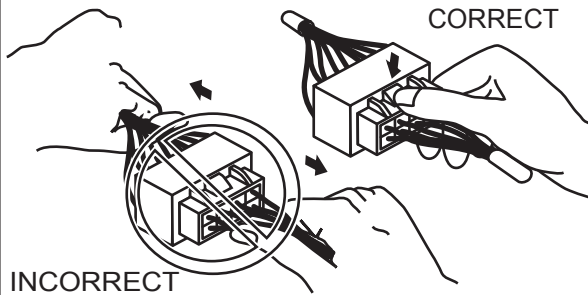

LOCKING CONNECTORS

When locking connectors, listen for a click, indicating they are securely locked.

Example:

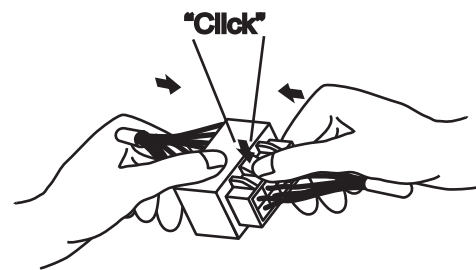

T-TAP INSTALLATION PROCEDURE

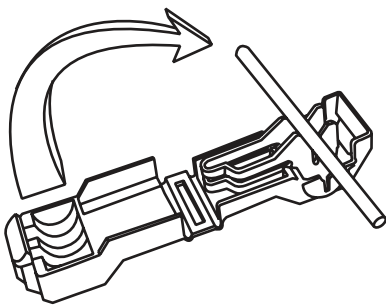

1. Place the T-Tap on vehicle wire.

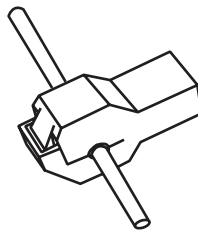

2. Using pliers, close, and crimp T-Tap around vehicle wire.

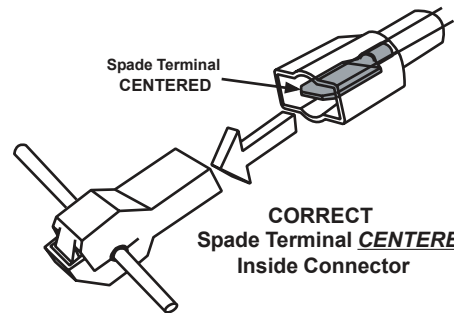

3. Insert EC Mirror Harness wire with male spade terminal end into the T-Tap.

****Extreme care must be taken to ensure that the male spade terminal is inserted into the T-Tap properly.**

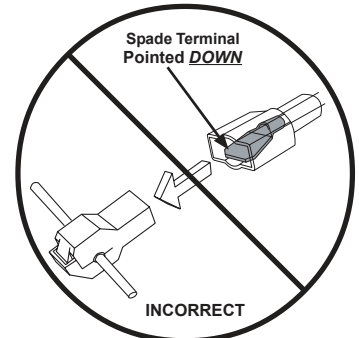
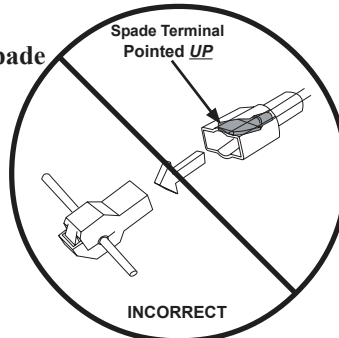

KIA Genuine Accessories

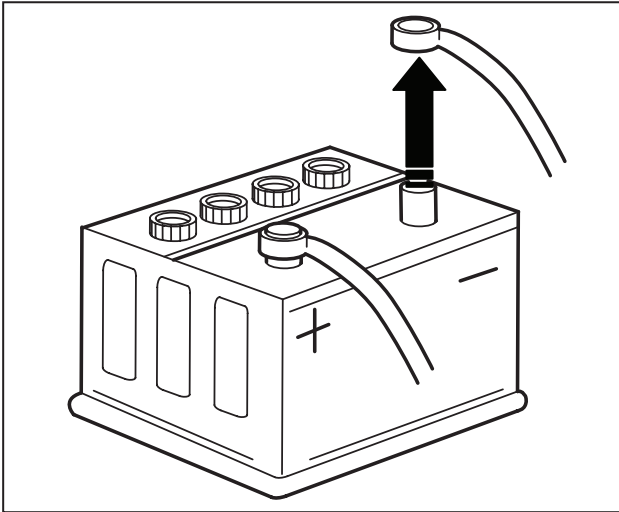

| | | |
|-------------|---|----------|
| | Ratchet & 10mm Socket | 1 |
| NOTE | <p>Ensure the correct part is being installed. Verify part number on the order request with the part number on the kit box label.</p> <p>Record all pre-set radio stations (if applicable).</p> <p>Disconnect and isolate vehicle's negative battery terminal.</p> | |
| | <p>WARNING: Shock Hazard. Do not touch vehicle's negative battery terminal to vehicle's positive battery terminal. Serious injury and damage to the vehicle may occur.</p> | |

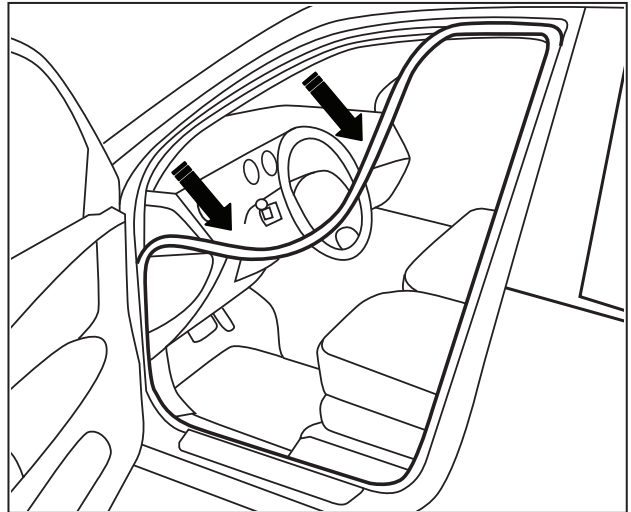

| | | |
|-------------|--|----------|
| | | 2 |
| NOTE | <p>Carefully pull front of driver-side door seal back to allow removal of A-pillar trim panel.</p> | |

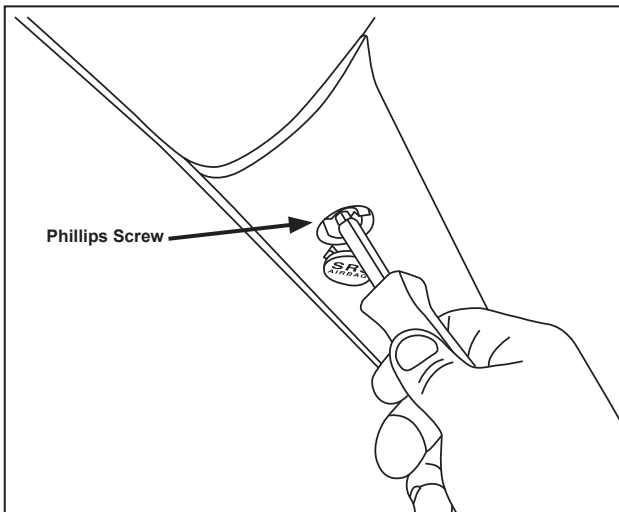

| | | |
|-------------|---|----------|
| | 4mm Flat Screwdriver & #2 Phillips Screwdriver | 3 |
| NOTE | <p>Insert 4mm flat screwdriver under screw cover in order to remove. Once cover is removed, remove one (1) Phillips screw from A-pillar trim.</p> | |
| | <p>Caution: Do not damage A-pillar trim.</p> | |

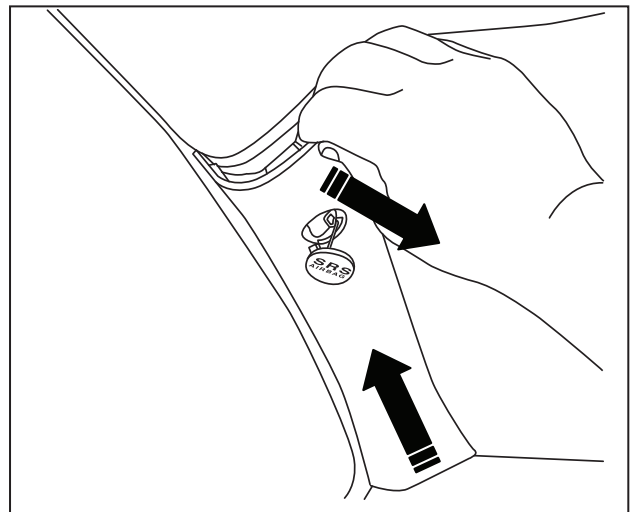

| | | |
|-------------|---|----------|
| | Nylon Panel Removal Tool | 4 |
| NOTE | <p>Remove A-pillar trim by pulling top out towards passenger-side of vehicle and then pulling base upwards toward roof of vehicle.</p> | |
| | <p>Caution: Ensure care is taken to prevent damage to A-pillar trim panel, wire harness, drain tube, and side curtain airbag unit.</p> | |

KIA Genuine Accessories

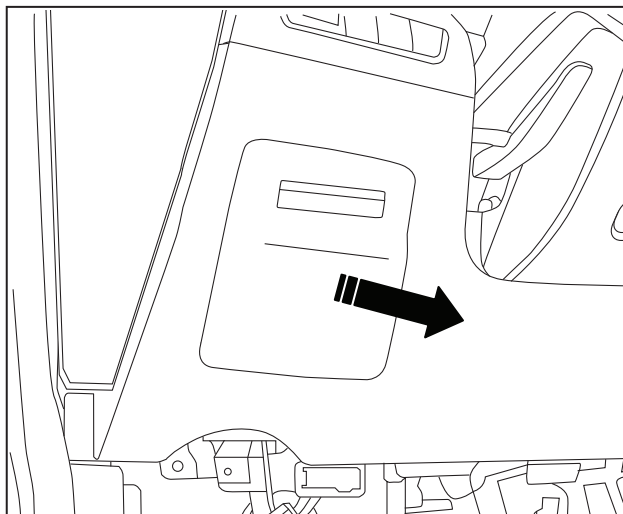

| | |
|-------------|---|
| 5 | |
| NOTE | Pull fuse panel cover out, towards driver in order to remove cover. |

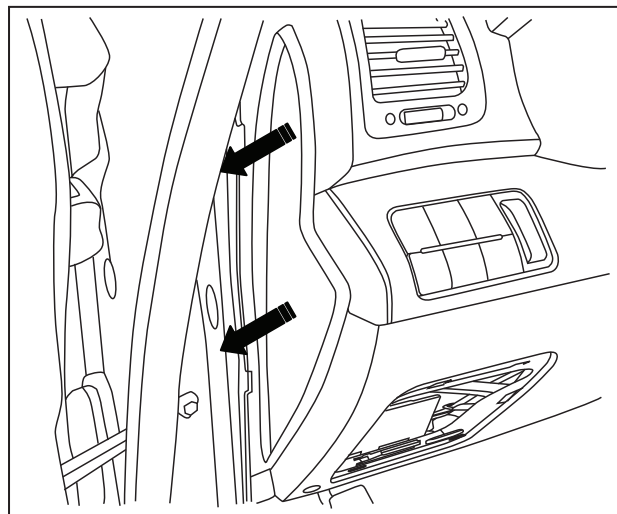

| | |
|-------------|---|
| 6 | Nylon Panel Removal Tool |
| NOTE | Using your hand, reach through the fuse panel access hole and press the back of the side dash trim panel outwards to partially dislodge the clips. Finish completely removing the side dash trim panel by using a nylon panel removal tool. |
| | Caution: Do not scratch side dash panel or lower dash trim panel. |

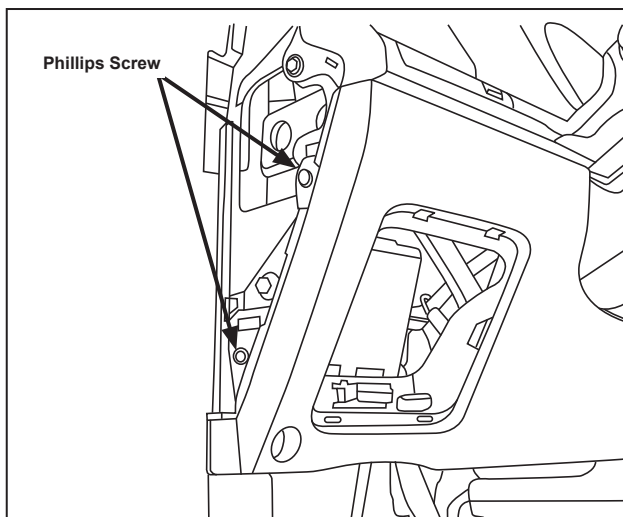

| | |
|-------------|--|
| 7 | #2 Phillips Screwdriver |
| NOTE | Remove two (2) Phillips screws from outside edge of lower dash trim panel. |
| | Caution: Do not scratch lower dash panel. |

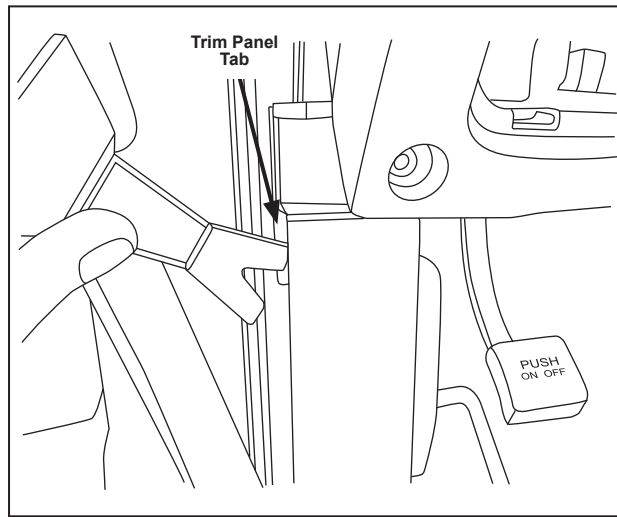

| | |
|-------------|---|
| 8 | Nylon Panel Removal Tool |
| NOTE | Insert nylon panel removal tool in between lower dash trim panel and side kick plate trim panel. Twist lower dash trim panel towards the front of the vehicle to release the one (1) locking tab. |
| | Caution: Do not damage lower dash trim panel or side kick plate trim panel. |

KIA Genuine Accessories

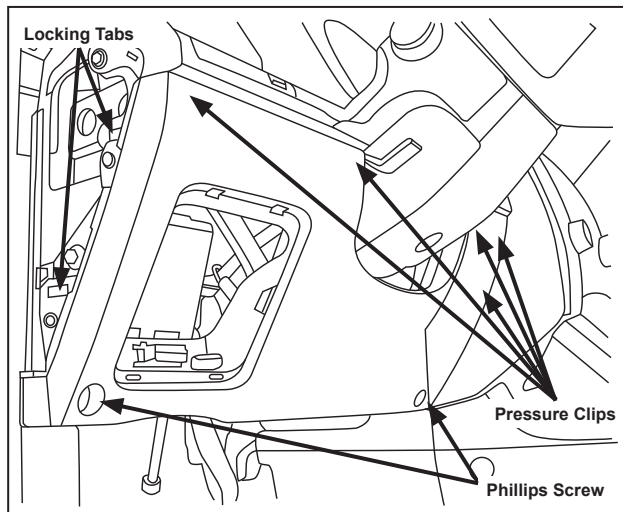

| | | |
|-------------|--|----------|
| | #2 Phillips Screwdriver & Nylon Panel Removal Tool | 9 |
| NOTE | Remove two (2) Phillips screws from right and left side of lower dash trim panel. Using nylon panel removal tool, release the two (2) locking tabs, next to the screw locations on side of dash trim panel. Pull away from the dash releasing the five (5) pressure clips. Remove panel until wires from OBD II connector are exposed, Unplug OBD II connector before completely removing dash trim panel. | |
| | Caution: Do not scratch lower dash trim panel. Do not damage wires or connectors in trim panel. | |

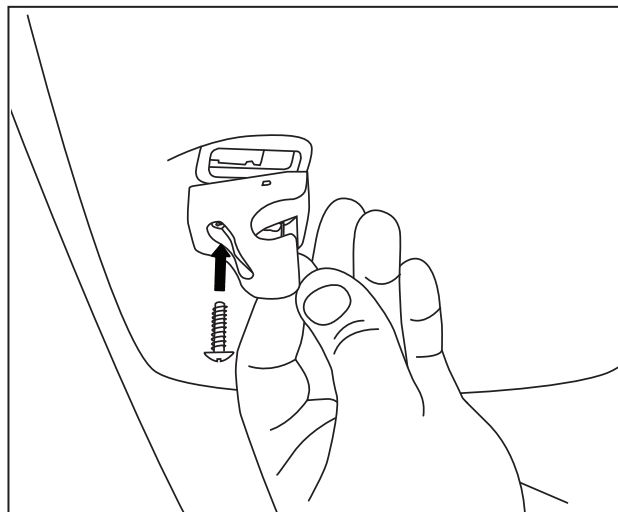

| | | |
|-------------|---|-----------|
| | #2 Phillips Screwdriver | 10 |
| NOTE | Partially remove driver-side sun visor hook by removing one (1) Phillips screw and let hook hang on retaining clip. | |
| | Caution: Do not damage sun visor hook or headliner. | |

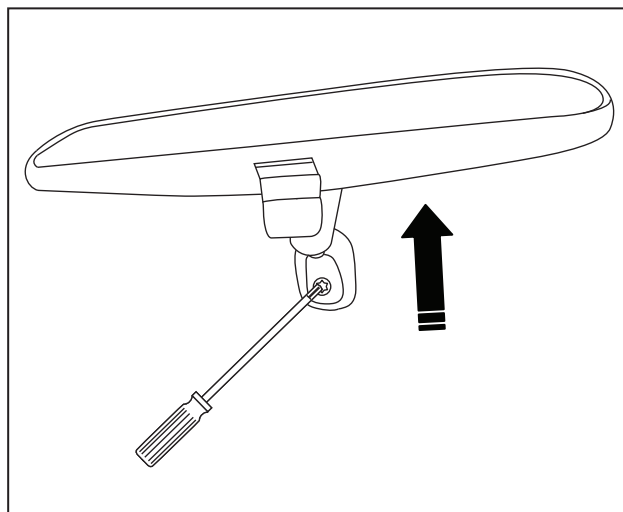

| | | |
|-------------|---|-----------|
| | T20 Torx Driver | 11 |
| NOTE | Loosen screw on mirror mount with a T20 Torx driver. Gently pull mirror upwards in a parallel direction to the windshield. DO NOT pull away from windshield. | |
| | Caution: Ensure care is taken to prevent damage to mirror mount, windshield, and headliner. | |

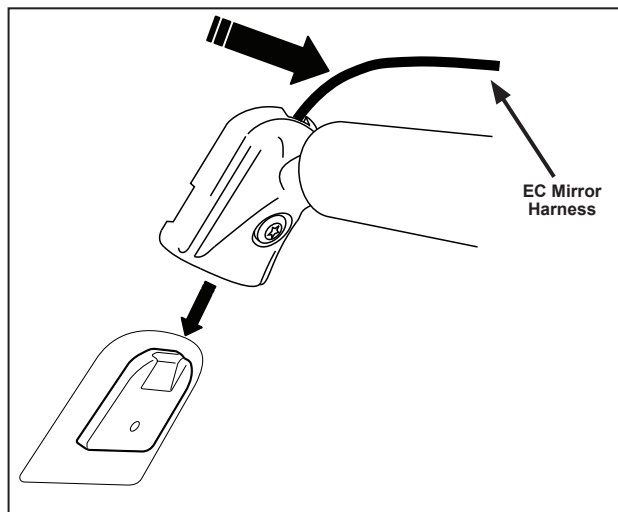

| | | |
|-------------|--|-----------|
| | | 12 |
| NOTE | Carefully pull harness lead extending out from EC mirror through the groove in the top of the mount before sliding mirror onto windshield button. Hold harness away from windshield when sliding EC mirror onto windshield button. | |
| | Caution: Ensure that EC Mirror Harness is not pinched between mount and windshield button. | |

KIA Genuine Accessories

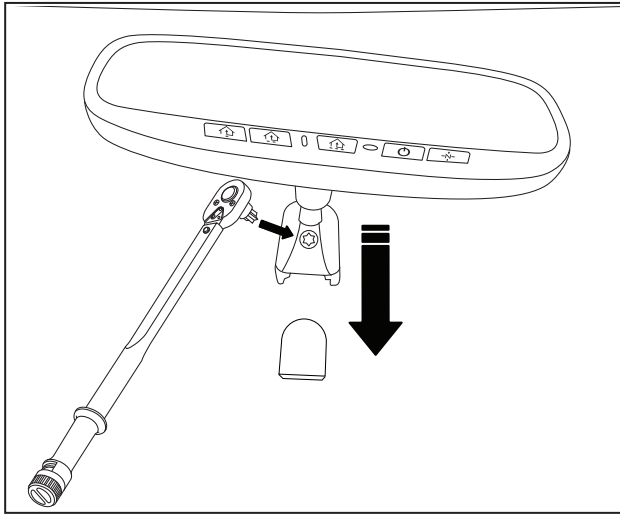

| | | |
|-------------|---|-----------|
| | T20 Torx Socket & Torque Wrench | 13 |
| NOTE | Slide EC mirror onto windshield button and tighten to 15.6 lb-in (1.8 N-m) using T20 Torx socket and Torque Wrench. | |
| | WARNING: Do not over tighten screw. Torque the mirror mounting bracket screw to 15.6 lb-in (1.8 N-m). Over tightening the screw won't properly secure the mirror and could cause the mirror to break loose and injure the vehicle's occupants. | |

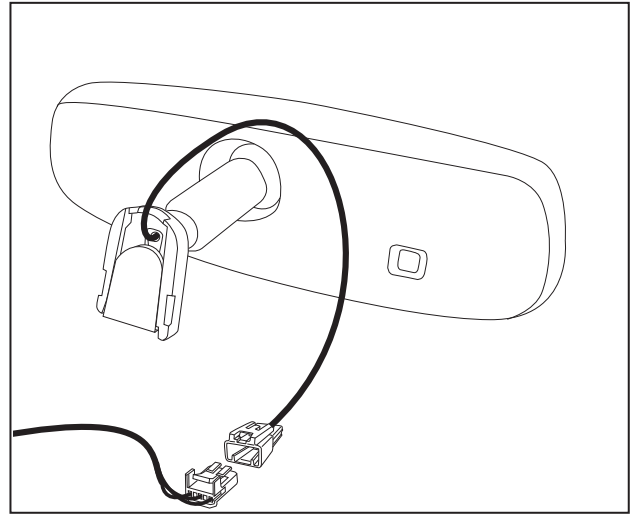

| | | |
|-------------|---|-----------|
| | | 14 |
| NOTE | Plug 5-pin connector from EC mirror harness into harness lead extending out from EC mirror. | |
| | Caution: Ensure 5-pin connector is securely installed. | |

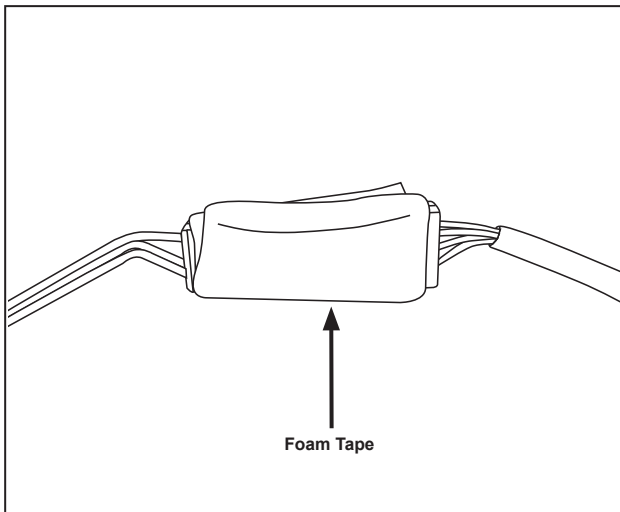

| | | |
|-------------|---|-----------|
| | | 15 |
| NOTE | Wrap one (1) piece of foam tape around EC mirror harness connector, as shown above. | |

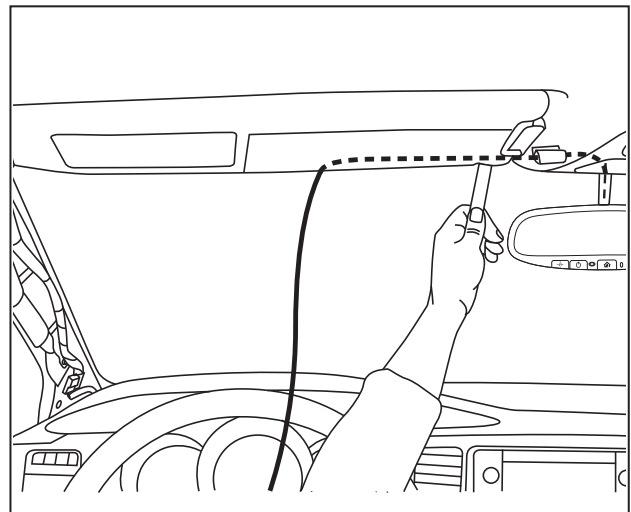

| | | |
|-------------|---|-----------|
| | Nylon Panel Removal Tool | 16 |
| NOTE | Begin tucking the EC mirror harness between the headliner and the roof. Stop just after the foam taped harness connector is tucked under the headliner. | |
| | Caution: Use caution when working with headliner to prevent creases or damage. Make sure your hands are clean. | |

KIA Genuine Accessories

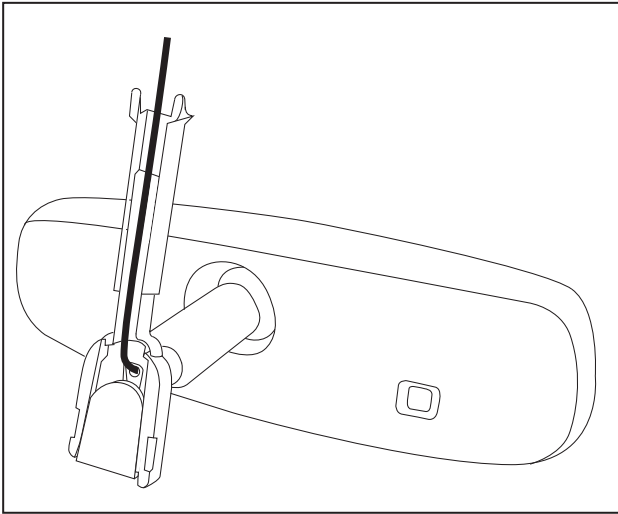

| | |
|------|--|
| 17 | |
| NOTE | Route harness lead extending out from EC mirror into groove of wire cover. Push the bottom of the cover into the mirror mount until it clicks and locks into place. Slide the top portion of the wire cover up until it extends fully into headliner. Ensure that the cover is vertical. |
| ⚠ | Caution: Ensure cover “forks” are properly seated into mirror and headliner. Ensure the cover is vertical before continuing. |

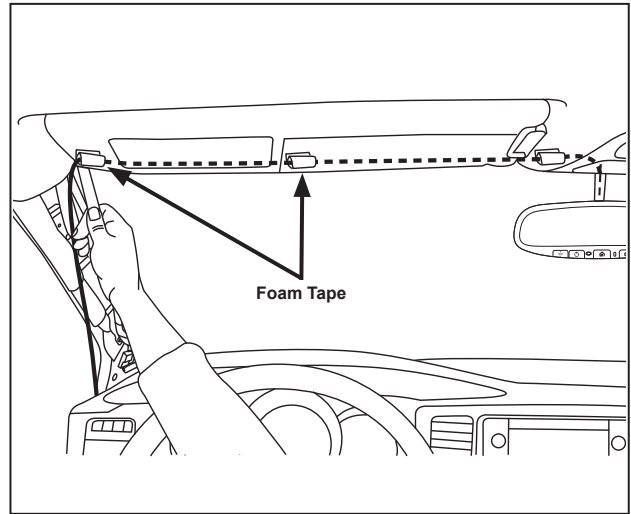

| | |
|------|--|
| 18 | Nylon Panel Removal Tool |
| NOTE | Wrap two (2) pieces of foam tape around EC mirror harness. Place the first piece approximately centered between the A-pillar and initial foam tape. Place the second piece just before the corner near the A-pillar. |
| | Tuck the harness with foam tape into the headliner from the mirror to the A-pillar. |
| ⚠ | Caution: Ensure harness wire cover is still vertical and that harness is completely tucked into headliner. |
| | Use caution when working with headliner to prevent creases or damage. |

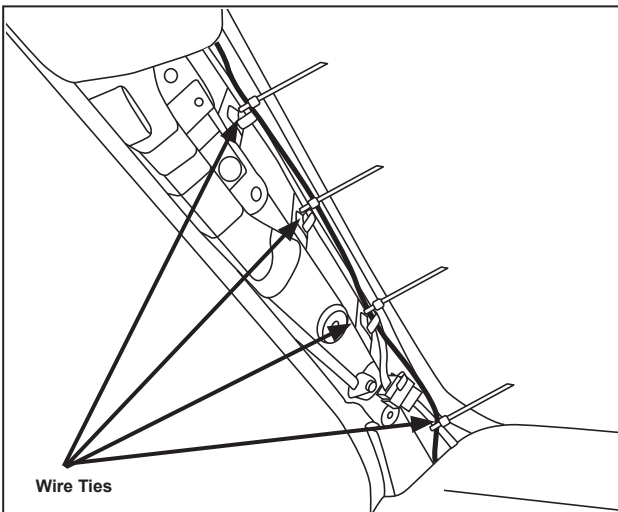

| | |
|------|---|
| 19 | Side Cutters |
| NOTE | When completing this step, ensure EC mirror harness does not interfere with airbag and ensure that harness is not secured to drain tube or airbag components. |
| | Route EC mirror harness down A-pillar and secure to OEM wire harness. Secure EC mirror harness near OEM clips with four (4) wire ties. |
| | Clip end of wire ties. |
| ⚠ | Caution: If vehicle is equipped with a sunroof, do not secure wire ties to drain tube. Be careful not to damage the OEM wire harness, the drain tube, or the side curtain air bag. |

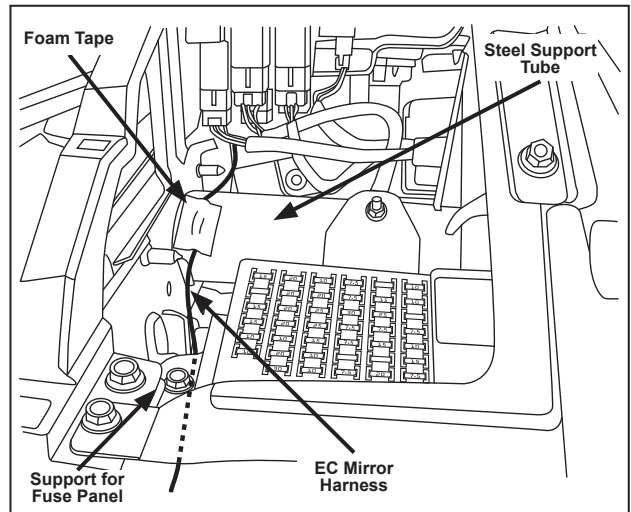

| | |
|------|---|
| 20 | |
| NOTE | Route EC mirror harness through dash, ensuring harness is routed to the rear of the steel support tube (side closest to the driver). Secure EC mirror harness to the far LEFT side of the steel support tube with one (1) piece of foam tape, as shown above. |
| | Continue to route the harness down to the connectors in the lower fuse panel by routing EC mirror harness to the front side of the left support for the fuse panel. |
| ⚠ | Caution: Ensure harness is not damaged during routing. |

KIA Genuine Accessories

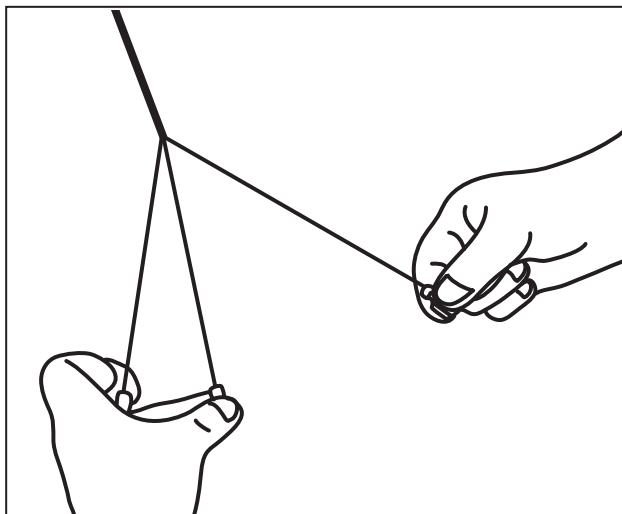

| | |
|------|---|
| 21 | |
| NOTE | Pull EC mirror harness wires apart approximately 10 inches, as shown. |
| ⚠ | Caution: <u>Do not</u> use a razor blade or any other tool to separate harness wires. Ensure harness is not damaged during separation. |

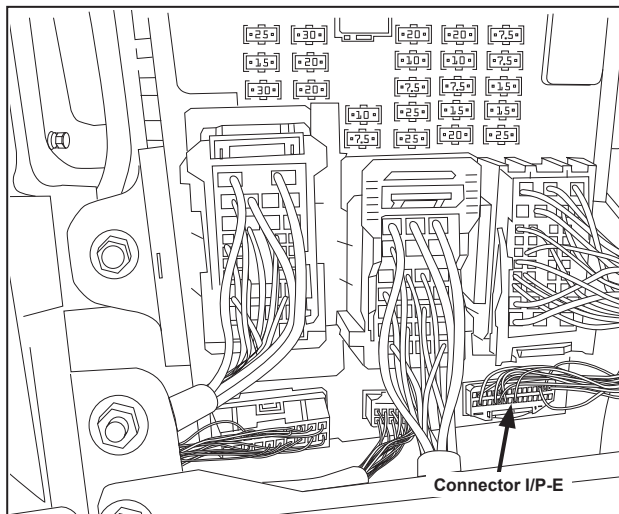

| | |
|------|---|
| 22 | |
| NOTE | Locate Connector I/P-E (32 pin connector) on the BOTTOM-RIGHT of the junction block. |
| ⚠ | Caution: Ensure that the correct connector is used. |

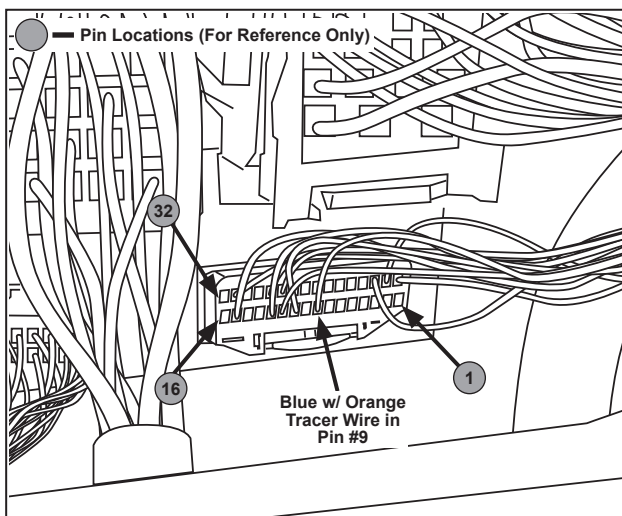

| | |
|------|---|
| 23 | |
| NOTE | Locate the BLUE w/ ORANGE Tracer wire in Pin #9 of Connector I/P-E. |
| ⚠ | Caution: Ensure that the correct wire is used. NOTE: Factory wire harness colors are subject to change, please use the specified pin # in the harness connector to identify the correct wire for T-Tap installation. |

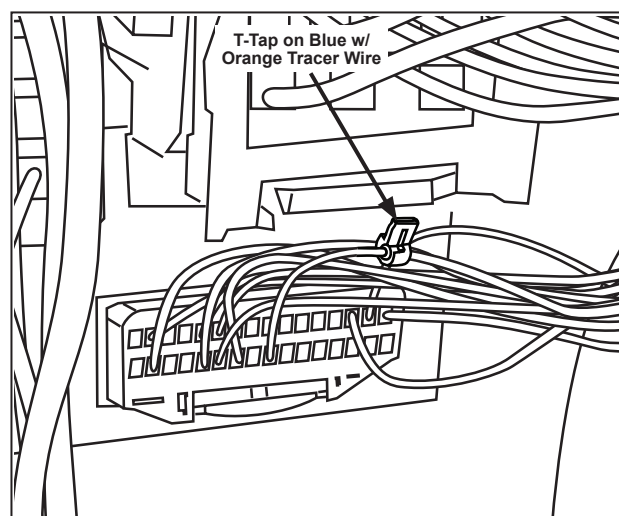

| | |
|------|---|
| 24 | |
| NOTE | Attach one (1) T-Tap to the BLUE w/ ORANGE Tracer wire in Pin #9 . Use pliers to snap T-Tap together. Reference page 3, "T-Tap Installation Procedure," for detailed instructions. |
| ⚠ | Caution: Ensure that the wire is in the slot of T-Tap and that both halves of T-Tap connector are snapped together properly. |

KIA Genuine Accessories

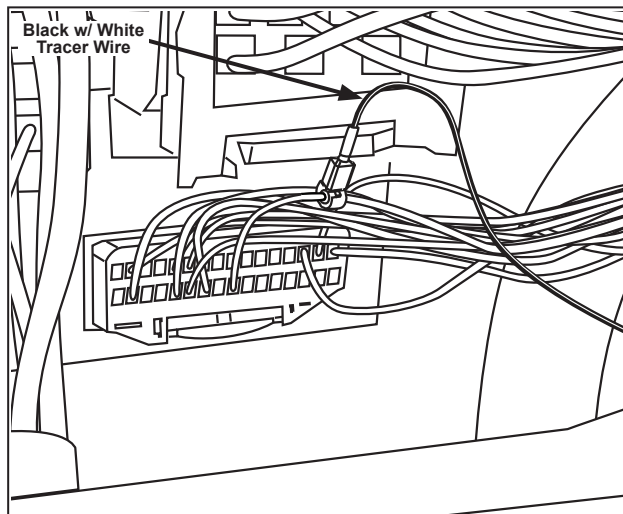

| | |
|-------------|--|
| 25 | |
| NOTE | Insert spade terminal of the BLACK w/ WHITE Tracer wire of EC mirror harness into T-Tap connector of BLUE w/ ORANGE Tracer wire (switched IGN 12 Volts). Reference page 3, "T-Tap Installation Procedure," for detailed instructions. |
| ⚠ | Caution: Ensure male spade connector is fully inserted into wire tap. Check to see that the spade connector did not miss the slot. Check to see that it is not visible on either side of female connector. |

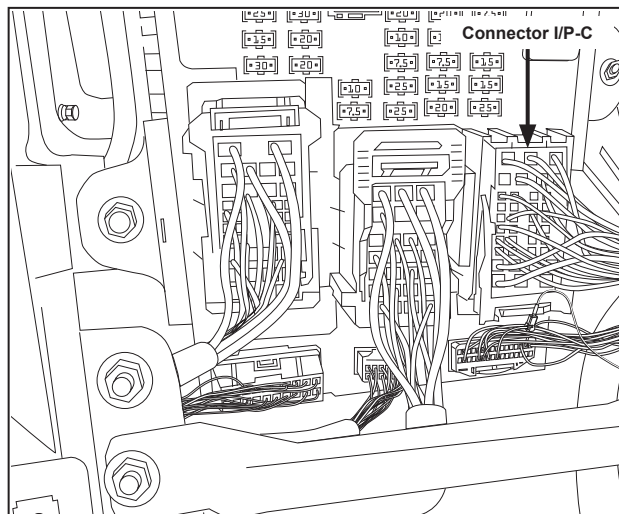

| | |
|-------------|---|
| 26 | |
| NOTE | Locate Connector I/P-C (38 pin connector) on the RIGHT side of the junction block. |
| ⚠ | Caution: Ensure that the correct connector is used. |

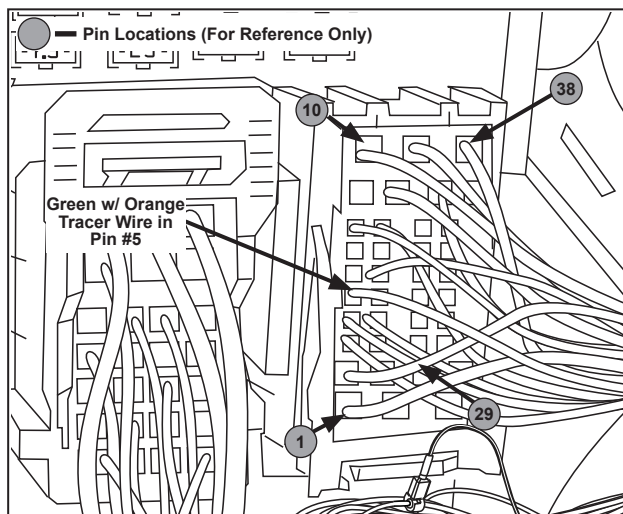

| | |
|-------------|---|
| 27 | |
| NOTE | Locate the GREEN w/ ORANGE Tracer wire in Pin #5 of Connector I/P-C. |
| ⚠ | Caution: Ensure that the correct wire is used. NOTE: Factory wire harness colors are subject to change, please use the specified pin # in the harness connector to identify the correct wire for T-Tap installation. |

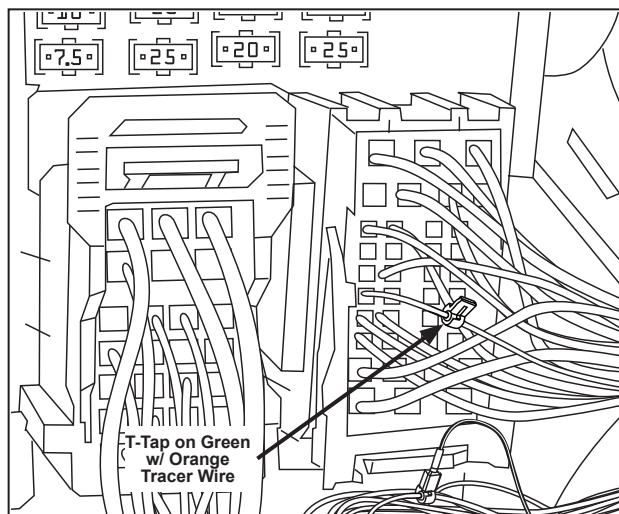

| | |
|-------------|---|
| 28 | |
| NOTE | Attach one (1) T-Tap to GREEN w/ ORANGE Tracer wire in Pin #5 . Use pliers to snap T-Tap together. Reference page 3, "T-Tap Installation Procedure," for detailed instructions. |
| ⚠ | Caution: Ensure that the wire is in the slot of T-Tap and that both halves of T-Tap connector are snapped together properly. |

KIA Genuine Accessories

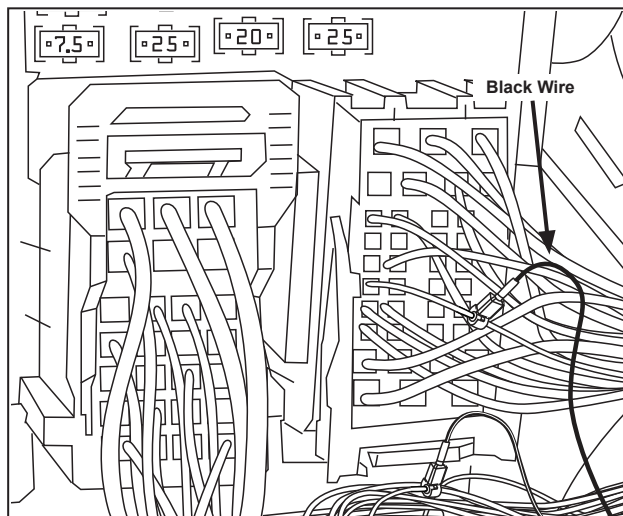

| | |
|-------------|---|
| | 29 |
| NOTE | Insert spade terminal on the solid BLACK wire of the EC mirror harness into T-Tap connector of the GREEN w/ ORANGE Tracer wire (constant 12 Volts) . Reference page 3, "T-Tap Installation Procedure," for detailed instructions. |
| | Caution: Ensure male spade connector is fully inserted into wire tap. Check to see that the spade connector did not miss the slot. Check to see that it is not visible on either side of female connector. |

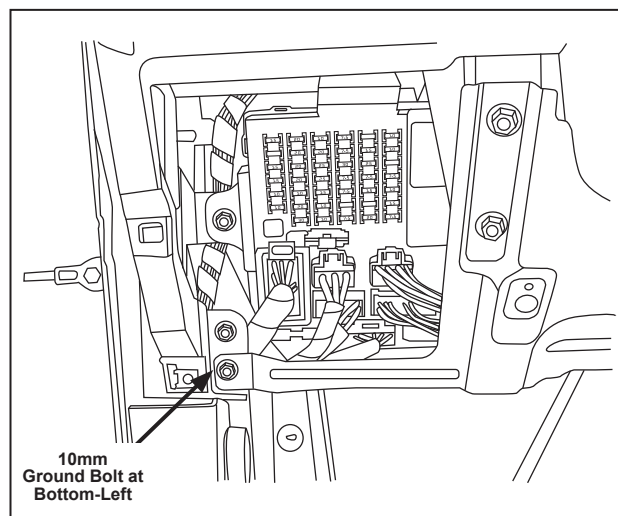

| | |
|-------------|--|
| | 30 |
| NOTE | Remove the bolt in the BOTTOM-LEFT of the steel knee bolster. |

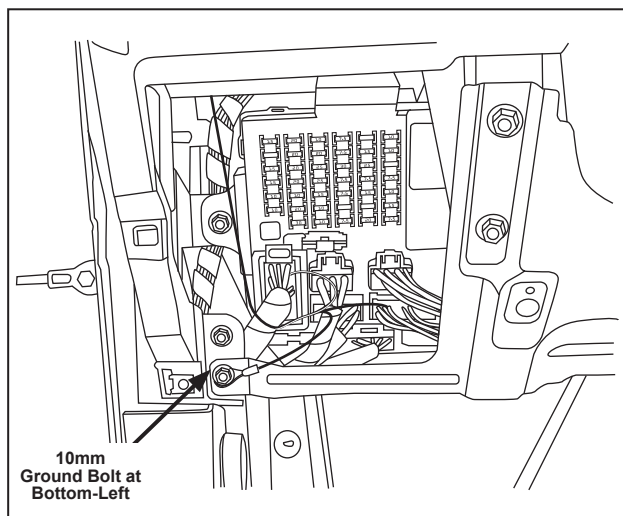

| | |
|-------------|---|
| | 31 |
| NOTE | Route ring terminal on Ground wire from EC mirror harness over the top and in front of knee bolster, as shown above. Reinstall the bolt in the BOTTOM - LEFT of the steel knee bolster plate by first inserting the ring terminal over bolt and threading through the knee bolster. Using 10mm socket and torque wrench, securely tighten bolt to a torque between 43.2 to 51.6 lb-in (4.9 to 5.9 N-m). |
| | Caution: Tighten the steel knee bolster bolt to a torque between 43.2 to 51.6 lb-in (4.9 to 5.9 N-m). Ensure ground bolt, with ring terminal and knee bolster, is securely tightened. Do not install ring terminal between knee bolster and dash. |

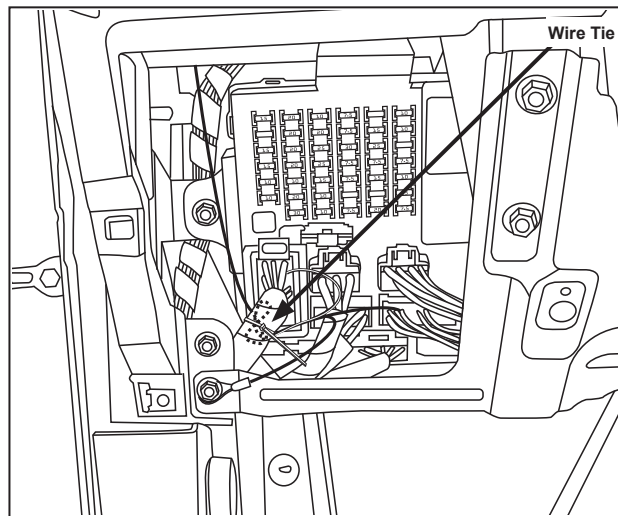

| | |
|-------------|--|
| | 32 |
| NOTE | Secure remaining EC mirror harness to the OEM wire harness, with one (1) wire tie <u>below the OEM wire harness</u> , as shown above. Clip end of wire tie. |

KIA Genuine Accessories

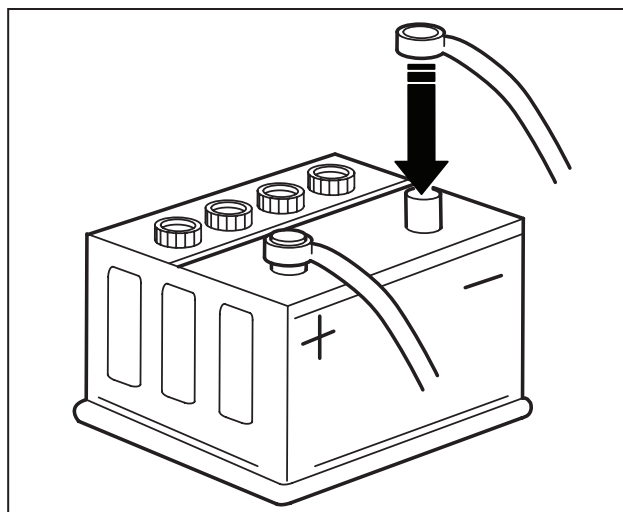

| | | |
|-------------|--|-----------|
| | Ratchet & 10mm Socket | 33 |
| NOTE | Testing Preparation: Reconnect negative battery cable, using 10mm socket. | |
| | WARNING: Shock Hazard. Do not touch vehicle's negative battery terminal to vehicle's positive battery terminal. Serious injury and damage to the vehicle may occur. | |

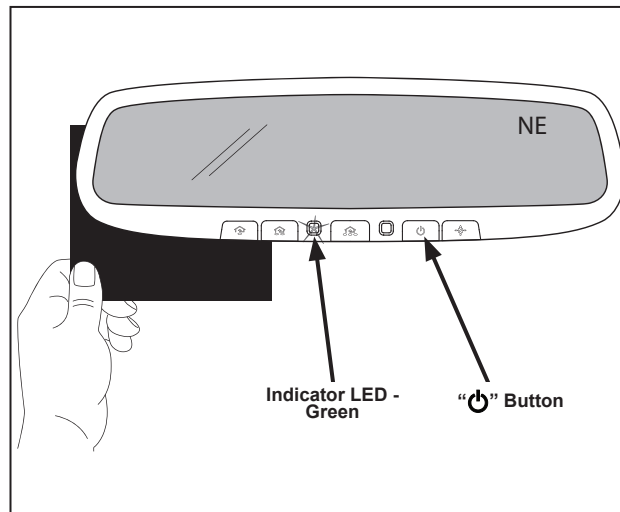

| | | |
|-------------|---|-----------|
| | | 34 |
| NOTE | Cover the forward looking photocell on the back of the mirror with a dark cloth or towel. Turn the ignition to the "ON" position. To make sure the auto-dimming feature is on, verify that the GREEN LED to the left of the center button is on. If it is not on, push the "ON" button to turn the GREEN LED on. At this time, the mirror will begin to darken. Remove the cloth from the forward looking photocell and the mirror will begin to clear. | |

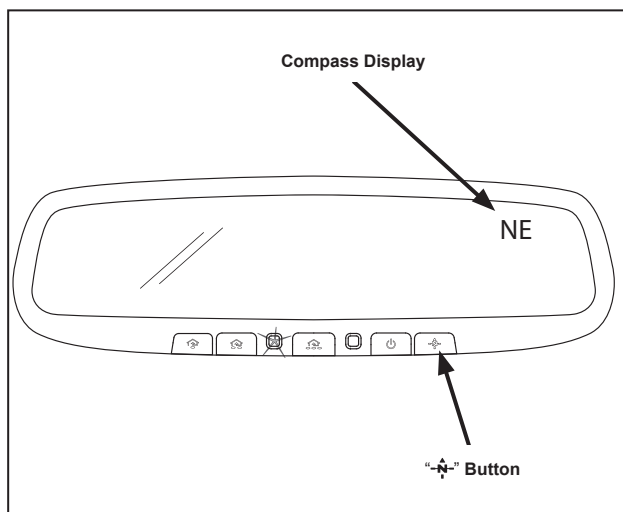

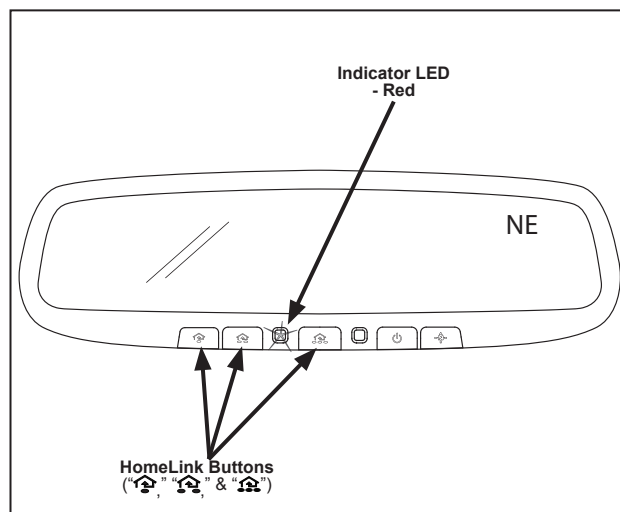

| | | |
|-------------|---|-----------|
| | | 35 |
| NOTE | Verify that either a direction, such as NE, or "C" is displayed in the display window. If not, ensure the compass feature is turned on by pressing the "N" button. | |

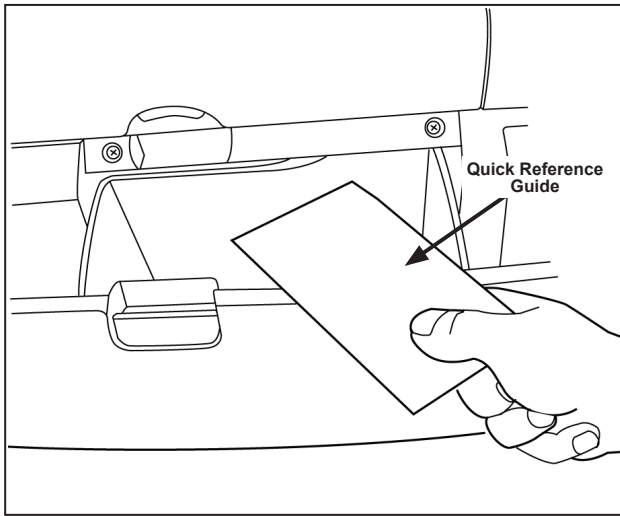

| | | |
|-------------|--|-----------|
| | | 36 |
| NOTE | Turn the ignition to the "OFF" position. Ensure that the Compass display is no longer visible and the Green LED is no longer on. Push each HomeLink button (" H ", " A " & " B "), one at a time, and verify that the LED indicator to the left of the center button illuminates with a RED LED when buttons are pressed. Testing is now complete. | |

KIA Genuine Accessories



| | |
|--|--|
|  | 37 |
| NOTE | Reinstall in reverse order, all remaining trim pieces removed during installation. Place Quick Reference Guide in vehicle glove box. Remove fingerprints, smudges, etc. from mirror and windshield. |
|  | Caution: DO NOT spray glass cleaner or other cleaning liquid directly onto the mirror as it may damage the electronics. |

KIA Genuine Accessories Calibration (DEALER INSTALL ONLY)

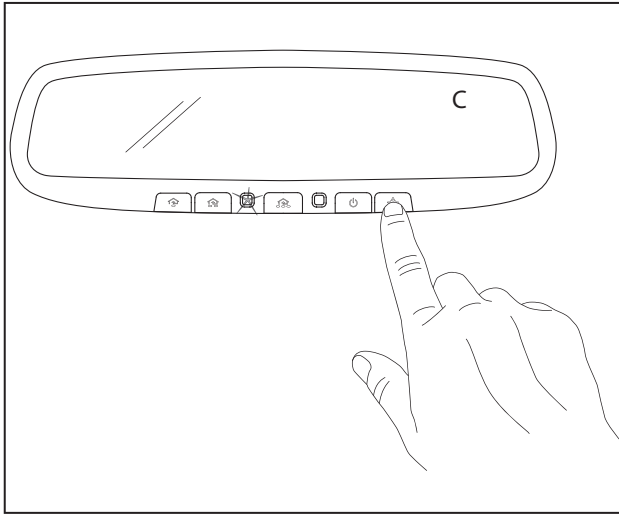

1

NOTE

If the display reads "C," the compass feature must be calibrated. To calibrate the compass, drive the vehicle in up to 3 complete circles at less than 5 mph.

To adjust for compass variance:
Press the "⏻" button for more than 9 seconds, or until the current Zone Number appears in the display.

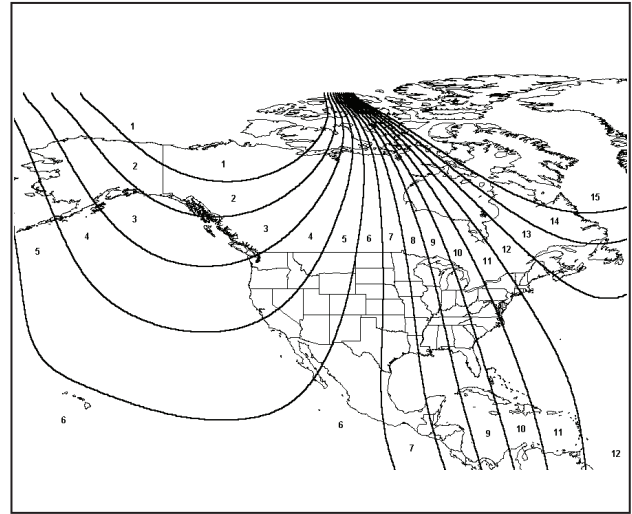

2

NOTE

Find your current location and variance Zone Number on the zone map, shown above. Press the "⏻" button until the new desired Zone Number appears in the display. Within a few seconds a compass direction will be displayed and the new zone is set.

KIA Genuine Accessories Visual Check

| | Items to Be Checked | Results Of The Check |
|---|---|---|
|  | Negative Battery Terminal Tightened  | Battery cable is correctly fastened to the negative terminal. WARNING: Shock Hazard. Do not touch vehicle's negative battery terminal to vehicle's positive battery terminal. Serious injury and damage to the vehicle may occur. |
|  | Ground Bolt | Bolt through bottom-left of steel knee bolster is securely tightened with ring terminal of ground wire properly attached. |
|  | EC Mirror Harness | EC mirror harness connector is securely fastened to lead extending out from EC mirror. Spade connectors are properly installed and ground ring is securely attached. EC mirror harness is not pinched or damaged. Ensure harness is tucked into headliner without causing a bulge or interference with headliner. |
|  | EC Mirror Wire Cover | Ensure upper portion of cover is properly seated onto lower cover, lower cover is properly seated on EC mirror mount, and that the "forks" are properly seated under headliner. Ensure cover is vertical without interference from harness. |
|  | EC Mirror Torx Screw | Torx screw is tightened to 15.6 lb-in (1.8 N-m). |
|  | Sun Visor Hook | Sun visor hook is securely in place and screw is properly tightened. |
|  | Lower Dash Trim Panel | Lower Dash Trim panel is securely in place with four (4) screws. OBD II connector is properly connected. |
|  | Side Dash Trim Panel | Trim panel is securely in place. |
|  | Fuse Panel Access Cover | Cover is securely in place. |
|  | Driver-side A-pillar Trim Panel | Trim panel is securely in place. Ensure Phillips screw is properly installed and tightened into steel A-pillar. |
|  | Driver-side Door Seal | Seal is properly in place. |
|  | EC Mirror Features: Auto-Dimming | EC mirror dims with ignition in the "ON" position when the forward looking photocell is covered. EC mirror is clear and does <u>NOT</u> dim with ignition in the "OFF" position and green LED is off. |
|  | EC Mirror Features: Compass Display | Compass display reads either "C" or a directional heading with ignition in the "ON" position only and <u>NOT</u> in the "OFF" position. |
|  | EC Mirror Features: HomeLink | Red LED illuminates when each HomeLink Button is pressed with ignition in both the "OFF" and "ON" positions. |

KIA Genuine Accessories Troubleshooting

| Items In Question | Results Of The Check | |
|--|--|--|
| Mirror harness is receiving the proper ignition switch signal. | <u>Instruction Reference</u> Step 22 - 25 (Installation) | Switched ignition harness wire, pin 4 at the EC mirror harness connector, is receiving +12V with ignition ON. |
| Mirror harness is receiving constant +12V power. | <u>Instruction Reference</u> Step 26-29 (Installation) | B+ harness wire, pin 3 at the EC mirror harness connector, is receiving +12V with ignition OFF. |
| Mirror harness is properly grounded at the ring terminal ground. | <u>Instruction Reference</u> Step 31 (Installation) | Ground is present at pin 1 at the EC mirror harness connector. |
| EC mirror harness is fully inserted into mirror harness lead extending out from EC mirror. | <u>Instruction Reference</u> Step 14 (Installation) | Harness connectors click when fully inserted into each other. |
| Spade terminals are correctly inserted into T-taps. | <u>Instruction Reference</u> Step 25 & 29 (Installation) | Ensure that male spade connectors are fully inserted into T-taps. Check to see that the spade connector did not miss the slot and that it is not visible on either side of female connector. |
| EC mirror harness is not pinched, cut, or damaged. | <u>Instruction Reference</u> Step 14 - 32 (Installation) | EC mirror harness is routed in a manner free of clips and pinch points of trim pieces. |

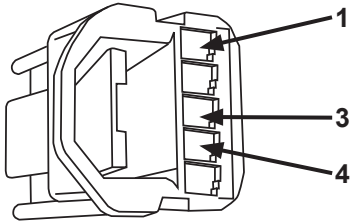

MIRROR CONNECTOR PIN-OUT

| NO. | GAGE | COLOR | FUNCTION | CIRCUIT | FUSE |
|-----|------|-----------------------------|------------------------------|------------------|-------------------------|
| 1 | 22 | Black | GROUND | | |
| 2 | | | | | |
| 3 | 22 | Black | BATTERY (constant 12 volts) | Clock Circuit | Interior Lamp 10 Amp |
| 4 | 22 | Black w/ White Tracer | IGNITION (switched 12 volts) | Audio Circuit | Module 4 10 Amp |
| 5 | | | | | |

KIA Genuine Accessories Troubleshooting

| Feature | Operation | Function | Primary Action | Secondary Action |
|--------------|--|---|--|---|
| HomeLink | Press each HomeLink Button independently | Red LED does not illuminate after any button is pressed | Check Interior Lamp Fuse 10 Amp Confirm spade connector is correctly inserted into T-tap (See page 3) Check for 12 Volts at T-tap on GREEN/ORANGE wire in pin 5 of I/P-C Connector. If no 12 Volts, wrap T-tap and install new T-tap (See page 3) Check vehicle grounds (refer to ETM) | If all checks are OK, replace Accessory EC Mirror |
| | | Red LED illuminates only for one or two buttons pressed | Replace Accessory EC Mirror | |
| Compass | Press Compass Button | Compass display does not illuminate | Check Module 4 Fuse 10 Amp Confirm spade connector is correctly inserted into T-tap (See page 3). Check for 12 Volts at T-tap on BLUE/ORANGE wire in pin 9 of I/P-E Connector. If no 12 Volts, wrap T-tap and install new T-tap (See page 3) Check vehicle grounds (refer to ETM) | If all checks are OK, replace Accessory EC Mirror |
| | | | | |
| Auto-Dimming | Press Power Button | Green LED does not illuminate | Check Module 4 Fuse 10 Amp Confirm spade connector is correctly inserted into T-tap (See page 3). Check for 12 Volts at T-tap on BLUE/ORANGE wire in pin 9 of I/P-E Connector. If no 12 Volts, wrap T-tap and install new T-tap (See page 3) Check vehicle grounds (refer to ETM) | If all checks are OK, replace Accessory EC Mirror |
| | | Green LED illuminates, but mirror does not darken | Replace Accessory EC Mirror | |

KIA Genuine Accessories Electrical Schematics

IGNITION

I/P-E Smart Junction Box Connector
- 32 Female / White

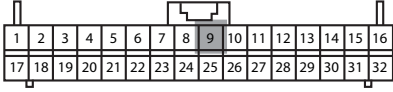

Pin # 9 - BLUE w/ ORANGE Tracer
Wire End View
Clock Circuit - Module 4 10 Amp Fuse

BATTERY

I/P-C Smart Junction Box Connector
- 38 Female / White

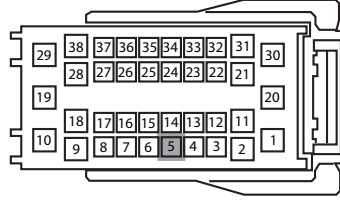

Pin # 5 - GREEN w/ ORANGE Tracer
Wire End View
OHC Lamp Circuit - Interior Lamp Fuse 10 Amp Fuse

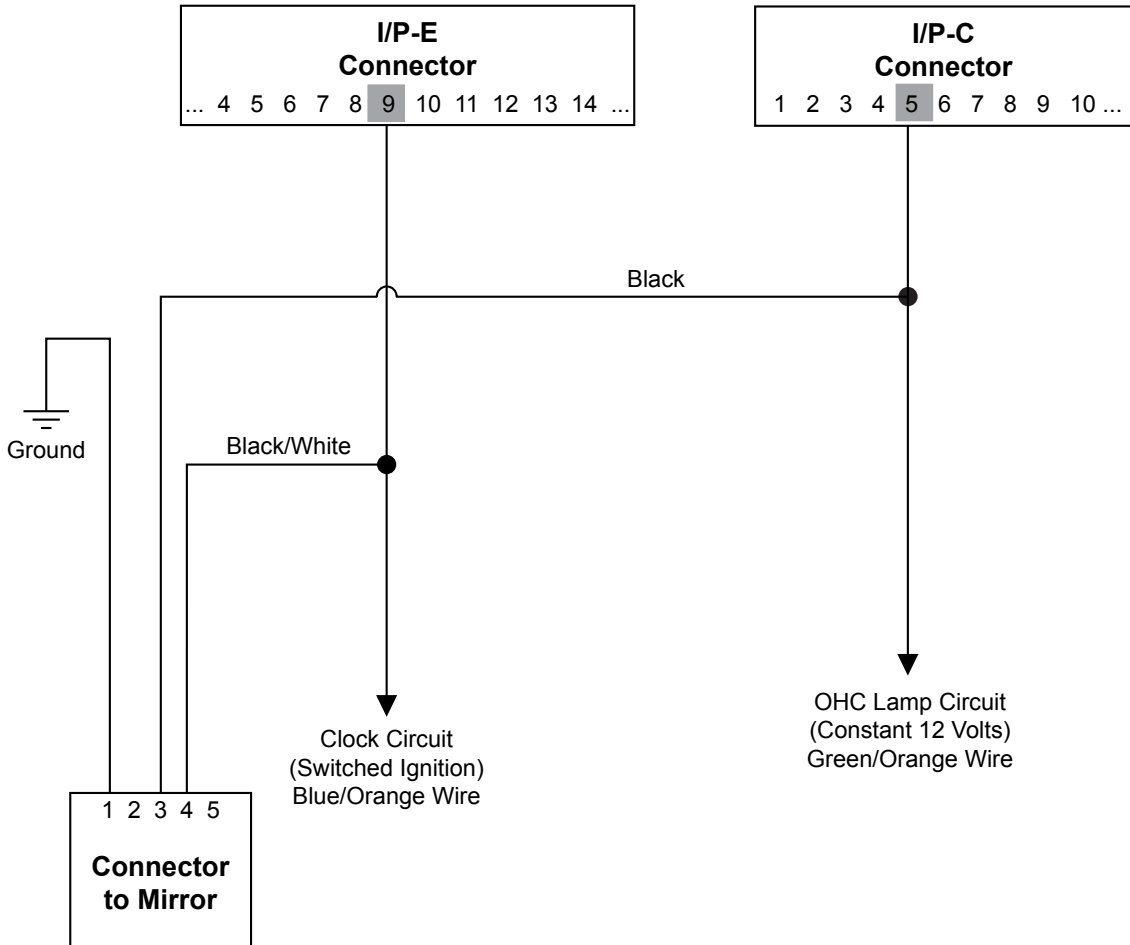

= Connector

—●— = T-Tap

Revision Date
1/24/2013